

## Product Specification and Applicable Scope

Description		Toilet Bowl Auto Sensor	
		AC	DC
Specification	Power source	110V/220V 60Hz	AA1.5V×4
	Power consumption	Less than 10W	100 times a day - two year
	Way of flushing	Two sections	
	Sensor distance	50 cm	
	Confirming time	About 3 seconds	
	1st speed flushing	About 1 second	
	2nd speed flushing	About 6 seconds	
	Water In-flow pipe size	PF 1/2	
	Outflow volume	Above 6 litres /min.	
	Applicable water pressure	0.3 to 6 Kg/cm <sup>2</sup>	
	Way of installation	Wall hanging type	
	External size	75.95×100.79×194mm	

- It will flush automatically after 24 hours when no one uses the toilet bowl.
- When the water pressure is more than 2Kgs, please install a pressure reducing valve.

## Urinal Flusher of Auto sensor

### Installation and Operation Manual

#### Cautions:

- Please read this manual carefully before installation and use.
- Upon completing the installation, please be sure to hand this manual to the customer.

503

7

## Adjustment of the water volume

Use the one-recess head screwdriver to turn the one-recess head screw on the solenoid to adjust the water flow.

Clockwise – reduce the water flow  
Counterclockwise – increase the water flow

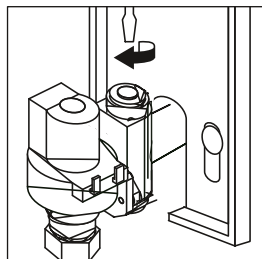

## Cleaning and Maintenance

When the outlet is clogged, take out the filter under the solenoid set to clean.

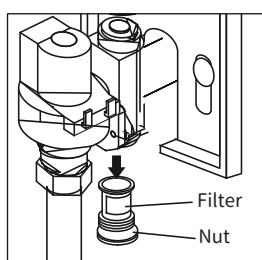

## Troubleshooting and Treatment

Problem	Possible cause	Treatment
Water keep flowing	1. Sensing area is unclean.	Wipe the outer casing with soft cloth or tissue.
	2. Solenoid is clogged.	Please call our service personnel.
No responding (with sensor light on)	1. Solenoid terminal not connected.	Connect the solenoid terminal again.
	2. Solenoid valve is out of order.	Please call our service personnel.
No responding	1. (AC) Power supply plug is not inserted.	Insert the plug.
	2. (DC) Insufficient battery power.	Please change a new battery.
	3. Circuit is broken.	Please call our service personnel.
	4. The object sensing more than 1 min.	Please remove the object.
Low water flow	1. Water inflow is too small.	Turn the triangle valve inflow bigger (refer to instruction of the adjustment).
	2. The filter is blocked.	Please remove items from the filter (refer to instruction of the cleaning and maintenance).

5

6

# Product Parts Disassemble Diagram

(AC)

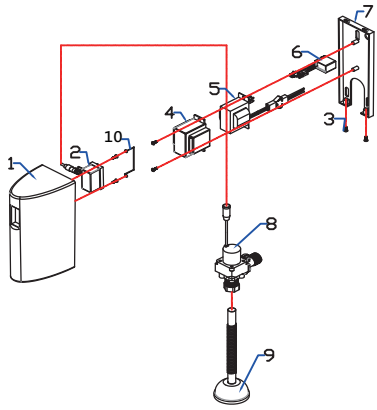

(DC)

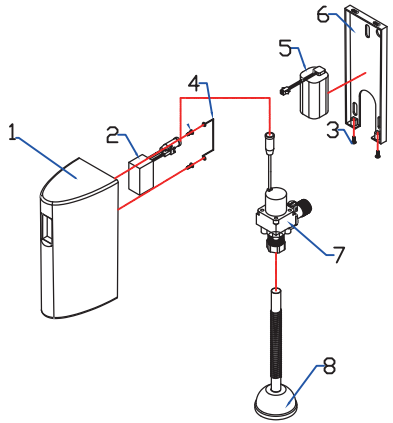

1

# Parts list

(AC)

Item	Description	Spec.	Q'ty	Remarks
1	Outer casing	ABS Plastic	1	
2	IR sensor	Plastic	1	
3	Countersunk screws	SUS304	6	
4	Transformer cover	Plastic	1	
5	Transformer	Silicon bronze	1	
6	Half-wave rectifier	Plastic	1	
7	Bottom plate	ABS Plastic	1	
8	Solenoid valve set	Copper, FRP	1	
9	Copper cup	Stainless Steel	1	
10	Transformer bracket	SUS304	1	

(DC)

Item	Description	Spec.	Q'ty	Remarks
1	Outer casing	ABS Plastic	1	
2	IR sensor	Plastic	1	
3	Countersunk screws	SUS304	3	
4	Transformer bracket	SUS304	1	
5	Battery set	AA 1.5V	1	
6	Bottom plate	ABS Plastic	1	
7	Solenoid valve set	Copper, FRP	1	
8	Copper cup	Stainless Steel	1	

2

# Standard Installation Diagram

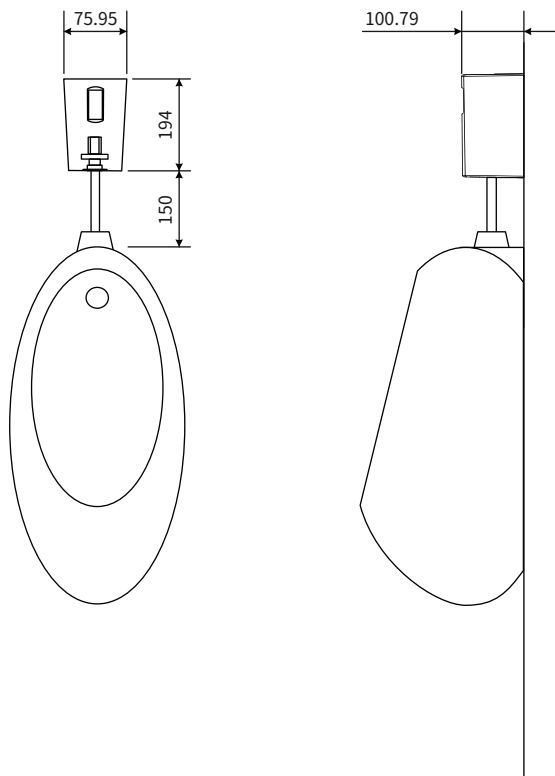

▪ Please install according to the actual ceramic size.

3

# Instruction for assembly of the sensor

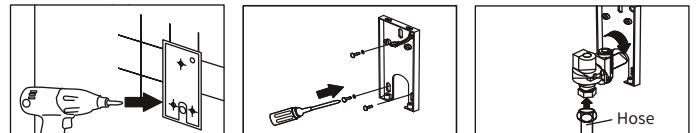

1. Stick the sticker on the wall of the installation and follow the instructions on the sticker.  
※Please shut off the electric power and water supply before installation.

2. After tearing off the sticker, install the sensor back case in the position where the hole has just been drilled and lock it.

3. Use the appropriate amount of the seal tape to surround the solenoid valve inlet. Then insert it into the water outlet of the wall in the clockwise direction and connect the hose on the urinal.

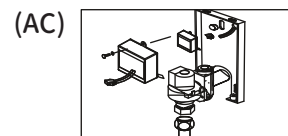

4. Lock the transformer's outer casing and transformer on the screw post on the back cover of the sensor.

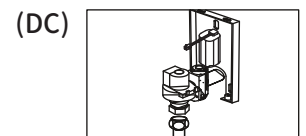

4. Stick the battery set (with the battery inside) in the proper position.

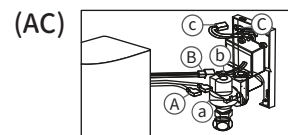

5. Connect the transformer and the connector on the solenoid valve and the connector on the sensor to each other according to the indication A→a / B→b / C→c on the diagram.

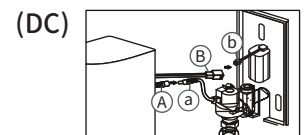

5. Connect the battery set to the connector on the solenoid valve and the connector on the sensor to each other according to the indication A→a / B→b on the illustration.

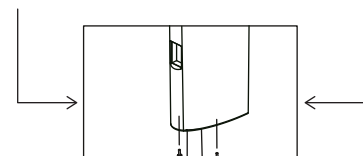

6. Cover the sensor front cover and lock the countersunk screws.

4